

Data sheet

Thermostatic sensor type RTS-K Everis™



Application



The RTS-K Everis™ is a liquid-filled self-actuating proportional controller with a small P-band for water-based central and district heating systems. The RTS-K Everis™ model features frost protection and facilities for limiting and locking the temperature set-point.

The sensor can be fitted without adaptor on valve radiators (compact radiators) from the manufacturers: Diatherm, Kermi, Korado, Purmo, Rettig and Radson.

Ordering and specifications

Type	Model	Temp. range ¹⁾	Code no.
RTS-K Everis™ 4250	Built-in sensor	8 - 28 °C	013L4250
RTS-K Everis™ 4270	Built-in sensor, limited temperature range	16 - 28 °C	013L4270

¹⁾ Temperatures stated for $X_p = 2$ K, i.e. the valve is closed at 2 °C higher room temperature.

Accessories

Product	Code no.
<p>Theft protection for RTS Everis™ sensors. Protection ring to prevent unintended removal of the sensor. No tools are required for mounting the protection ring. Colour: White RAL 9016.</p>	013G5287

Mounting

The RTS-K Everis™ sensor is supplied with a nut for connection on valves with M 30 x 1.5 connection.

During mounting the setting dial should be in position 5.

The connection nut should be tightened with an open-end 32 mm spanner.

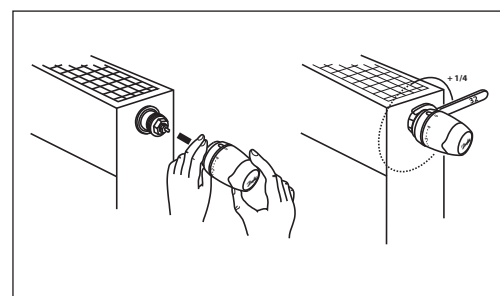

Setting the temperature

$X_p = 0$ K

$X_p = 2$ K

* = Frost protection setting.
Room temperature scale for $X_p = 2$ °C

The temperature scale is stated according to European standards at $X_p = 2$ °C. This means that the radiator thermostats close at a sensor temperature

which is 2 °C higher than stated on the temperature scales.

Dimensions

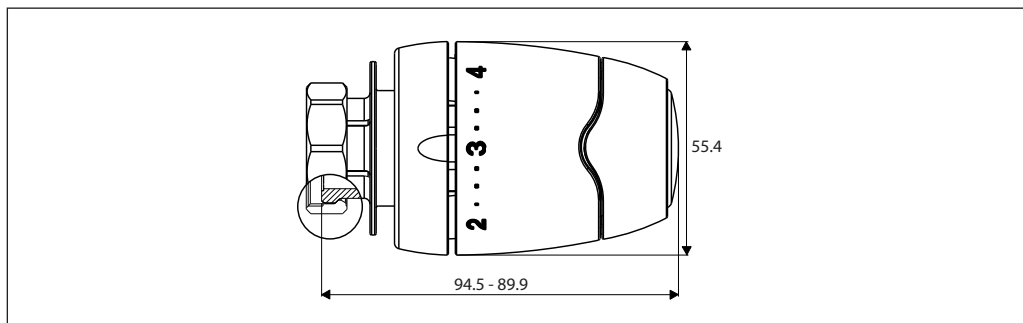

Danfoss can accept no responsibility for possible errors in catalogues, brochures and other printed material. Danfoss reserves the right to alter its products without notice. This also applies to products already on order provided that such alterations can be made without subsequential changes being necessary in specifications already agreed. All trademarks in this material are property of the respective companies. Danfoss and the Danfoss logotype are trademarks of Danfoss A/S. All rights reserved.