



Verifying the flow on DN40/50 to DN100 AB-QM valves

Flow verification in an installation

To verify that an installation functions according to the design specifications checking only the most critical valve in the installation is needed (see principle figure 1).

The AB-QM maintains a constant differential pressure over the valve and any excess pressure will automatically be throttled. If there is not enough differential pressure the valve cannot reach the set flow. The valve that is furthest away from the pump or the valve in the circuit with the highest resistance has the lowest available differential pressure, so if this critical valve has enough pressure it means the other valves will also function properly.

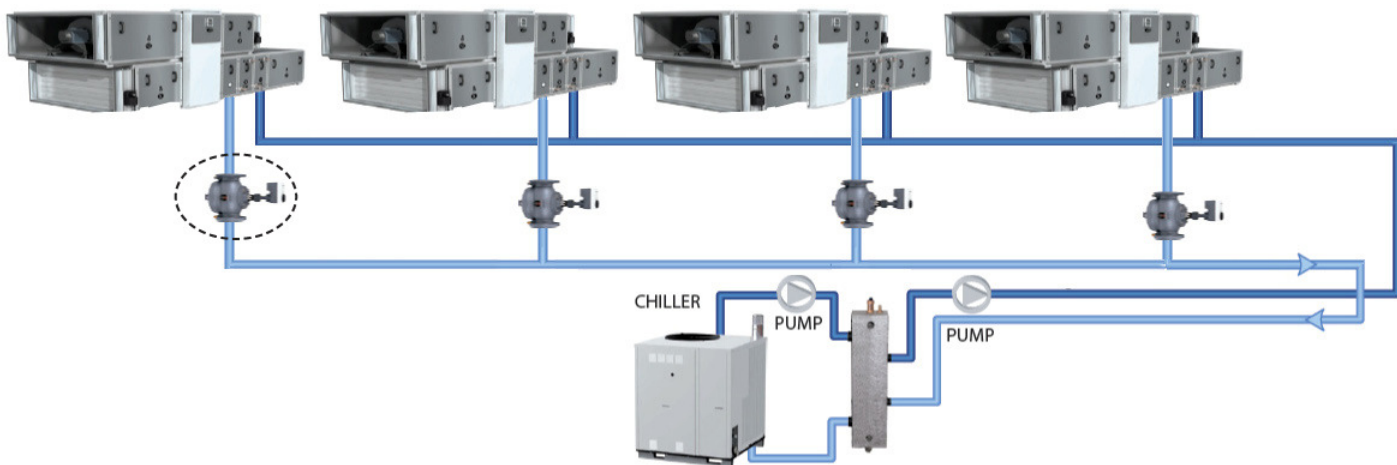

Fig. 1

Important: To get a useful measurement the installation should run on full load, so all actuators in the installation should be opened fully. This ensures that you are measuring under the most unfavourable circumstances. The AB-QM's will have more differential pressure available when the installation is working on partial load.

Method of verification:

- Measure the differential pressure across the measuring nipples of the AB-QM. The measuring nipples are placed in such a way that differential pressure ΔP over the valve is measured (see figure 2).

If the measured value is below 30 kPa then there is not enough differential pressure available for the AB-QM to function properly. If the measured value is above 30 kPa then the AB-QM has enough differential pressure available and the flow is according to the setting (see figure 3).

Setting the flow:

DN40/50: 1 turn=12, 5% (0,8 turn=10%)

DN65 to DN100: 1 turn=10%

Note: for more information about setting procedure please refer to instructions.

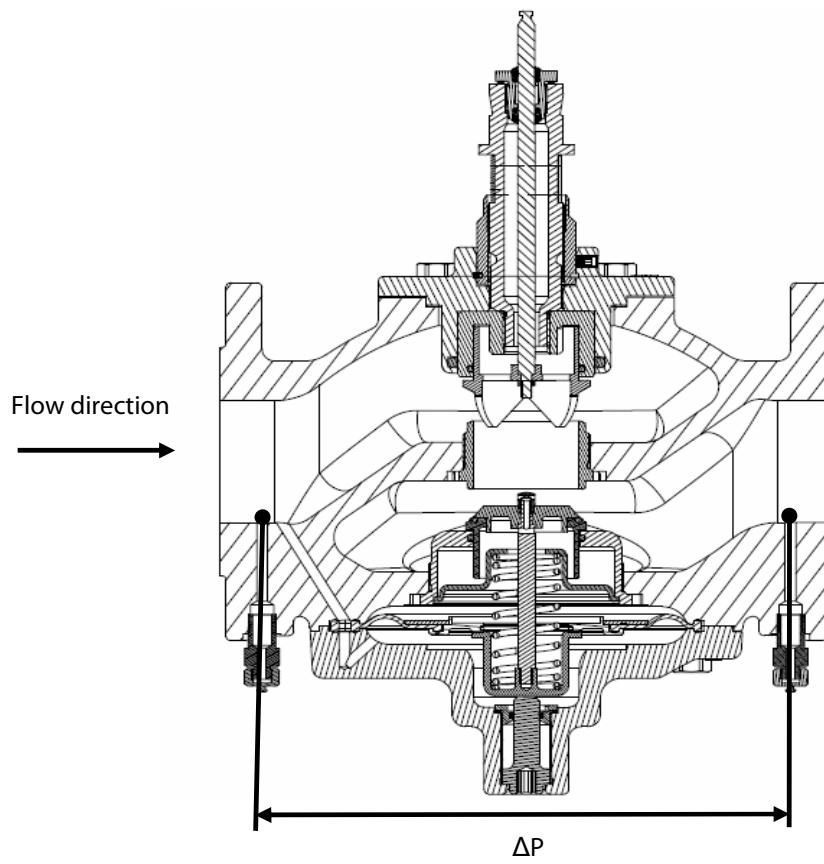

Fig. 2

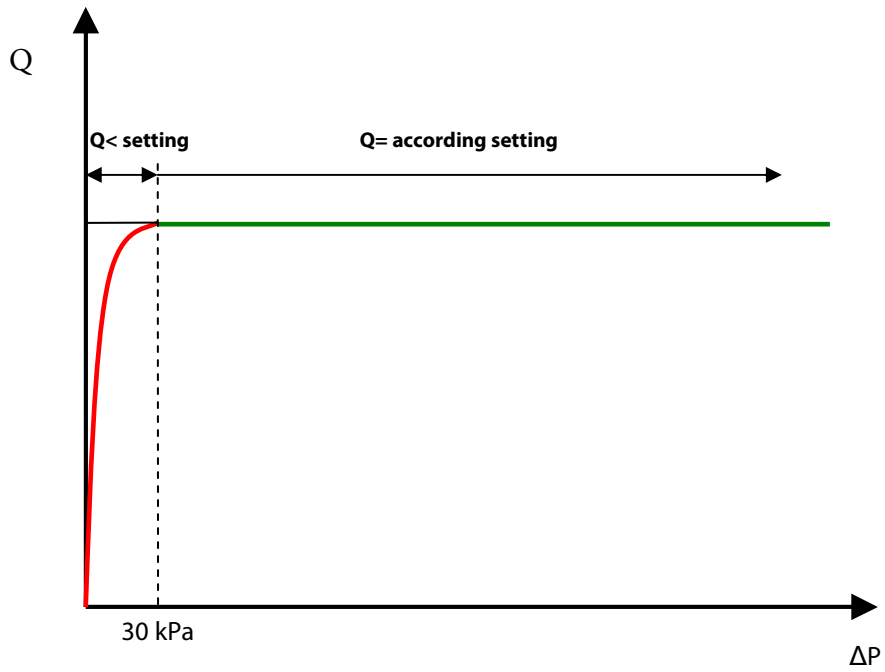

Fig. 3