

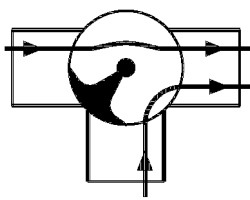

HRB 3



HRB 4



HRB 3 mixing

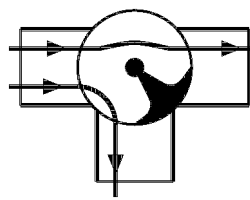

HRB 3 diverting

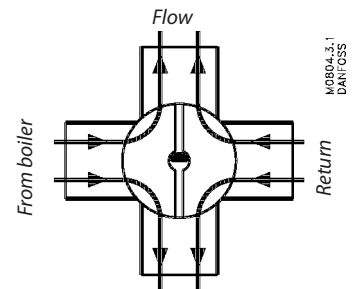

AMB 162, AMB 182 + HRB

1

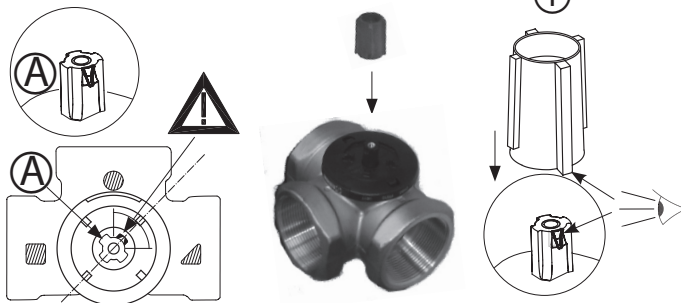

2

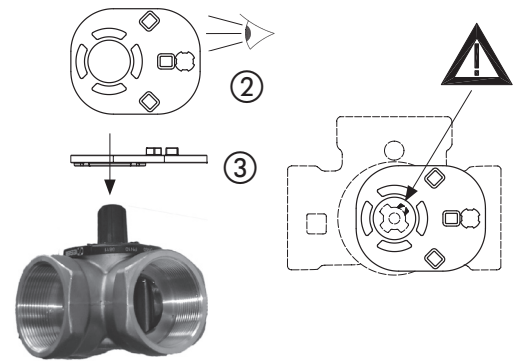

3

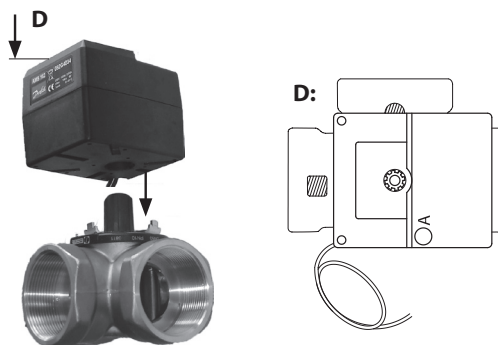

4

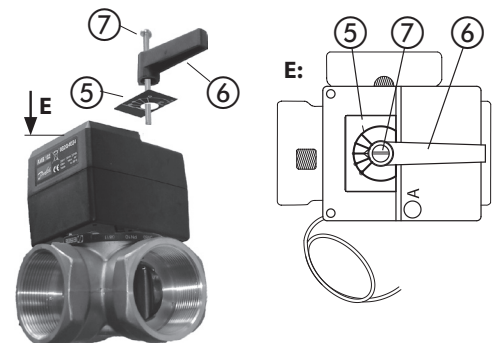

HRB 3

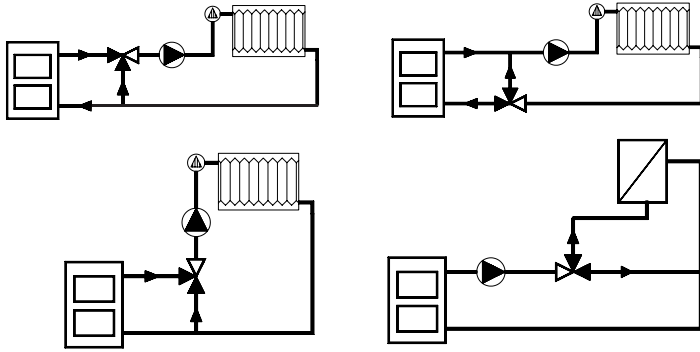

max. t: 110°C  
min. t: 0°C

max. P: 10bar

max. P: 16bar

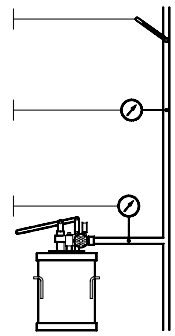

DANFOSS  
AMB162.10

HRB 4

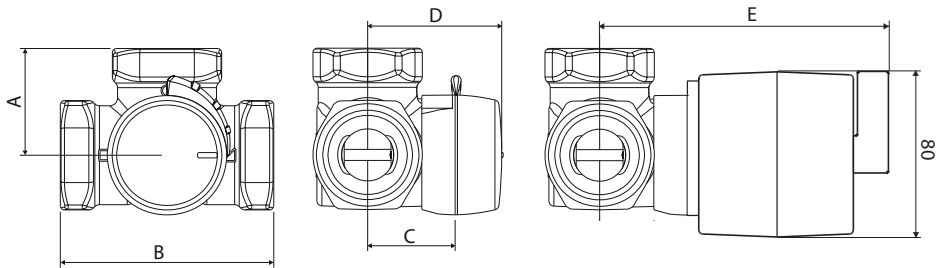
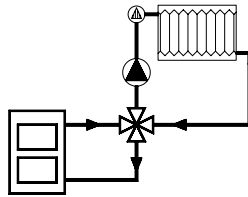

HRB 3

Size	mm				Weight (kg)	E mm	Actuator
	A	B	C	D			
DN 15	36	72	32	50	0.40	128	AMB 162 AMB 182
DN 20	36	72	32	50	0.43	128	
DN 25	41	82	34	52	0.70	130	
DN 32	47	94	37	55	0.95	133	
DN 40	58	116	44	62	1.75	140	
DN 50	62	125	44	62	2.05	140	

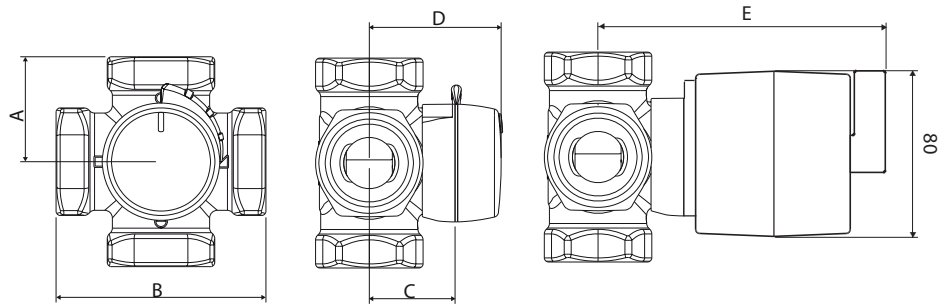
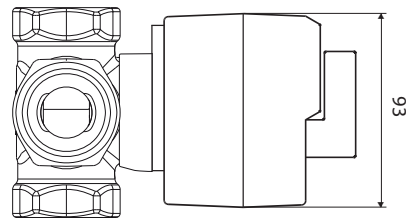

HRB 4

Size	mm				Weight (kg)	E mm	Actuator
	A	B	C	D			
DN 15	36	72	32	50	0.40	128	AMB 162 AMB 182
DN 20	36	72	32	50	0.52	128	
DN 25	41	82	34	52	0.80	130	
DN 32	47	94	37	55	1.08	133	
DN 40	58	116	44	62	2.25	140	
DN 50	62	125	44	62	2.30	140	

