



103E7
*7-Day Electronic Timeswitch
for Controlling Hot Water and Heating
(Including Factory Replacement Units FRU)*

For a large print version of these instructions please call Marketing on 0845 121 7400.



Certification Mark

This product complies with the following EC Directives:
Electro-Magnetic Compatibility Directive.
(EMC) (2004/108/EC)
Low Voltage Directive.
(LVD) (2006/95/EC)



Danfoss can accept no responsibility for possible errors in catalogues, brochures, and other printed material. All trademarks in this material are property of the respective companies. Danfoss and the Danfoss logotype are trademarks of Danfoss A/S. All rights reserved.

103E7

*7-Day Electronic Timeswitch
for Controlling Hot Water and Heating*

GB



Index

1.0 Installation Overview	4
2.0 Product Specification	4
3.0 Installation	4
3.1 Wiring.....	6
4.0 Replacement	10

1.0 Installation Overview

Please Note:

This product should only be installed by a qualified electrician or competent heating installer and should be in accordance with the current edition of the IEEE wiring regulations.

2.0 Product Specification

Specification	
Power Supply	230Vac, $\pm 15\%$, 50 Hz
Switching Action	1 x SPST, Type 1B
Switch Rating	264Vac, 50/60Hz, 3(1)A
Setting/Running Accuracy	± 1 min./month
Power Reserve	Minimum 24 hours
Max. Ambient Temperature	45°C
Dimensions, mm (W, H, D)	102 x 136 x 47
Design Standard	EN 60730-2-7
Control Pollution Situation	Degree 2
Rated Impulse Voltage	2.5kV
Ball Pressure Test	75°C

3.0 Installation



NB. For FRU units - go straight to point 6.

1. Loosen the fixing screw in the base of the unit to release the Wiring Cover.
2. Holding the unit face downwards, press firmly in the centre of the wallplate and slide it apart and lift it from the module.

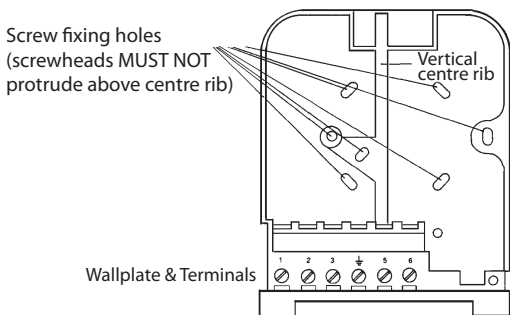
- Fix the wallplate and terminal block to the wall, or plaster box, as required. Ensure that the screw heads do not protrude beyond the vertical centre rib of the wallplate, or this will prevent the module correctly locating onto the wallplate.



- Surface cables can only enter from below the unit. Cut an appropriate cable aperture in the wiring cover. If the wallplate is mounted on a plaster box, cables can enter from the rear below the terminal block.
- Electrical connections are simplified by using a Wiring Centre. However, if this is not used, the wallplate terminal identification is as shown.

Load			Mains Supply (via 3 amp fuse)		
ON	SPARE	COM		N	L
1	2	3		5	6

If the system being controlled is 230 Vac, then terminals 3 and L must be linked with insulated cable capable of carrying full load current. Whilst the unit does not require an earth connection, a terminal is provided on the wallplate for earth continuity purposes.

- Refer to the wiring diagrams on page 6-9, connect the unit as shown.

7. Find out from the user whether the unit is required to operate in **7-day mode (factory preset)** or **weekday/weekend mode (5/2 day)**. To convert to 5/2 day mode remove the small two-way connector from the pins towards the left of the recess on the rear of the module, then press the button marked **R/S** under the flap to **RESET** the unit.
8. Ensure all dust and debris are cleared from the area. Plug the module into the wallplate by locating it onto the wallplate and, when flush with it, sliding it down, ensure the hook at the top of the wallplate engages with the slot at the back of the module.
9. Before setting the programme, check the unit and circuit. Press the **SELECT** button until the bar in the display lines up with the word **ON**. Adjust the remote thermostats to check the system operates correctly.
10. Then press the **SELECT** button until the bar lines up with the word **OFF** and check the system does not operate.
11. When the circuit check has been completed, replace the wiring cover and tighten the fixing screw. Cut any cable aperture in the wiring cover which may be necessary to accommodate surface mounted cables.
12. Finally set time of day and programmes required, noting that the unit is supplied with a pre-set programme, see User Guide.

3.1 Wiring

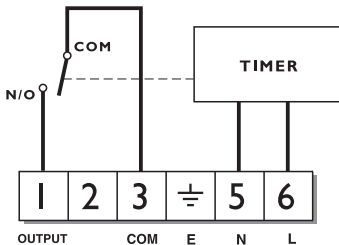

Typical Gravity DHW with Pumped Heating

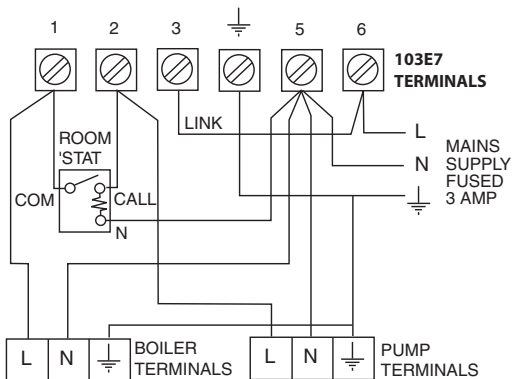

GB

Typical Control of Pump for Central Heating on a Solid Fuel System

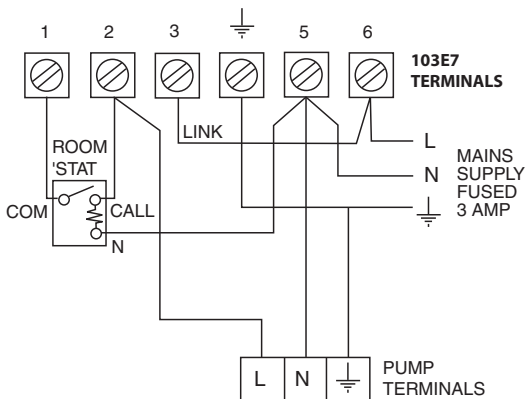

Typical Heating Only System, Boiler and Pump Control

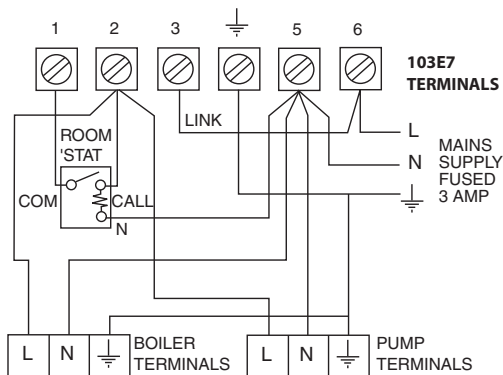

Typical Control of Low Voltage System requiring Voltage Free Contacts

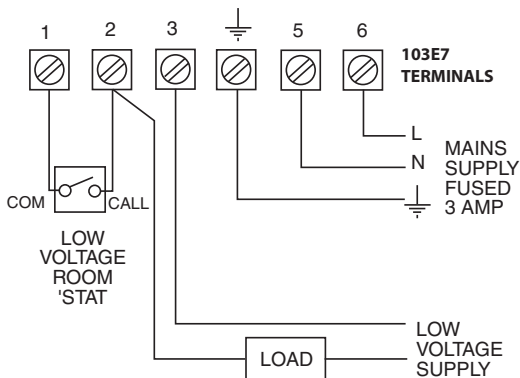



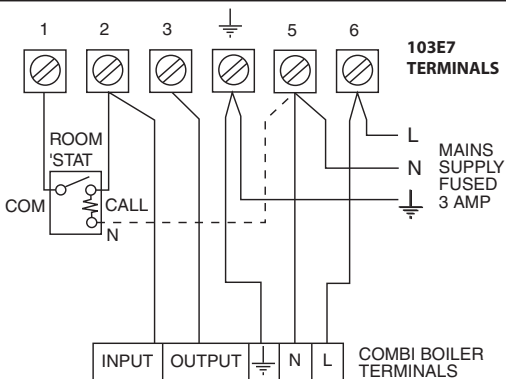





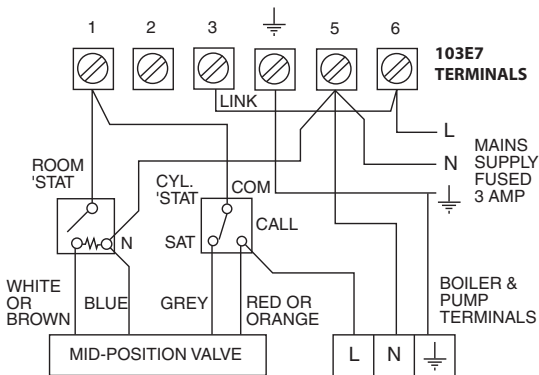

Typical control of Heating when provided by Combination type Boiler (see note below)













Note: Connection - - - - - must only be made if input/output of boiler are 230V signals

Typical Heating and Hot Water Control System using 3 Port Mid-position Valve



DANFOSS RANDALL 103E7	LOAD			MAINS SUPPLY (via 3 amp fuse)			An additional terminal block is required where these disconnected leads (or pairs of leads) should be terminated			
	ON	SPARE	COM	5 (N)	6 (L)	A	B	C	D	
										2
RANDALL 103, 103E, 103E7	1	2	3							
RANDALL 3020	4	2	-		1,7	3	5			
RANDALL TSR2	5	4	1		3	2	6	7		
GRASSLIN 45, 45A, 45E	4	-	3		2	1				
HORSTMANN 424 EMERALD & PEARL AUTO RANGE	4	2	3		N	L,1	5			
HORSTMANN 423 PEARL, EMERALD & TOPAZ	4	1	3		N	L	2	5	6	
SANGAMO S254 Form 2, S408 Form 5, S251 Form 2	LOAD	-	-		N	L				
SANGAMO S610 F2, S611 F2, S612 F2, S408 F4, S408 F6, S253 F2, S255 F2	LOAD	-	SWITCH LIVE		N	MOTOR LIVE				
SANGAMO S409 Form 8	2	1	6		3,N	5,L				

DANFOSS RANDALL 103E7	LOAD			MAINS SUPPLY (via 3 amp fuse)			An additional terminal block is required where these disconnected leads (or pairs of leads) should be terminated			
	ON	SPARE	COM		5 (N)	6 (L)		A	B	C
SANGAMO/RANDALL SET 1	1	2	3		N	L				
SMITHS IND. MKI, MKII	4	2	5		N	L				
SMITHS IND. CENTROLLER 30	P3	P1	P2		N	L				
SMITHS IND. CENTROLLER 40	4,5	3	-		1	2	6			
SWITCHMASTER 300	4,5	3	-		1	2				
TOWERCHRON TC	1	2	4		N	L	3			
VENNER VANNERETTE MKIIA	7	3	4		2	1	8	9	10	11
VENNER VANNERETTE MKIVA	LOAD	-	LINE		N	L				
VENNER VANNERON P	1	-	4		2	3				
VENNER VANNERON P	4	-	1		3	2				



Danfoss Randall Ltd.

Amphill Road
Bedford MK42 9ER

Tel: 0845 1217 400

Fax: 0845 1217 515

Email: danfosrandall@danfoss.com

Website: www.danfoss-randall.co.uk